

The logo consists of the letters 'RS' in a bold, white, sans-serif font, centered within a red square. The background of the entire page is a blurred image of a compass rose with degree markings (280, 300, 320, 340) and cardinal directions (NW, N). A red diagonal shape cuts across the top-left corner. A faint hexagonal grid pattern is overlaid on the background, with various icons like a cloud with signal waves, a fingerprint, and a Wi-Fi symbol integrated into it.

RS

WHERE AM I?

Location Services with
Bluetooth

NO.RS-ONLINE.COM

Image: Mario Aranda, pixabay

 Sensors
 Connectivity
 Security

WHERE AM I?

Location Services with Bluetooth

[From Version 5.1, Bluetooth](#) can be used as a precise indoor positioning application. This technology can determine the presence, distance and direction of a target.

These Bluetooth location services can offer solutions for the following applications:

- **Asset Tracking** - the tracking function can locate things and people. Examples might be tools or employees in a warehouse or medical equipment and patients in a hospital.
- **Indoor Navigation** - in airports, train stations, exhibition halls and shopping centres. Bluetooth provides navigation to the destination with IPS (Indoor Positioning System) in buildings where the Global Positioning System (GPS) does not work. This is done with an inaccuracy of less than one metre.
- **Digital Key** - with the digital key, you can use a smartphone as a secure key to unlock doors and rooms when approaching the 'lock' of an apartment or office building.
- **Item Finding** - helps find missing items. When a tagged object is misplaced, the user launches an application on their smartphone to locate it precisely.

According to the Bluetooth Special Interest Group (SIG), the use of Bluetooth location services devices is expected to increase by 25% per year over the next five years (Fig. 1).



Fig. 1. 25% CAGR for devices with Bluetooth location services from 2022 to 2026. (Image: Bluetooth SIG)

According to Bluetooth SIG, the latest inventory and logistics challenges are driving the demand for transport and storage solutions. Analysts agree that among Bluetooth Location Services solutions, asset tracking (RTLS) and tags are the main drivers of growth. Commercial RTLS systems, including healthcare, account for the largest volume of equipment shipments this year (2022) (Fig. 2.).

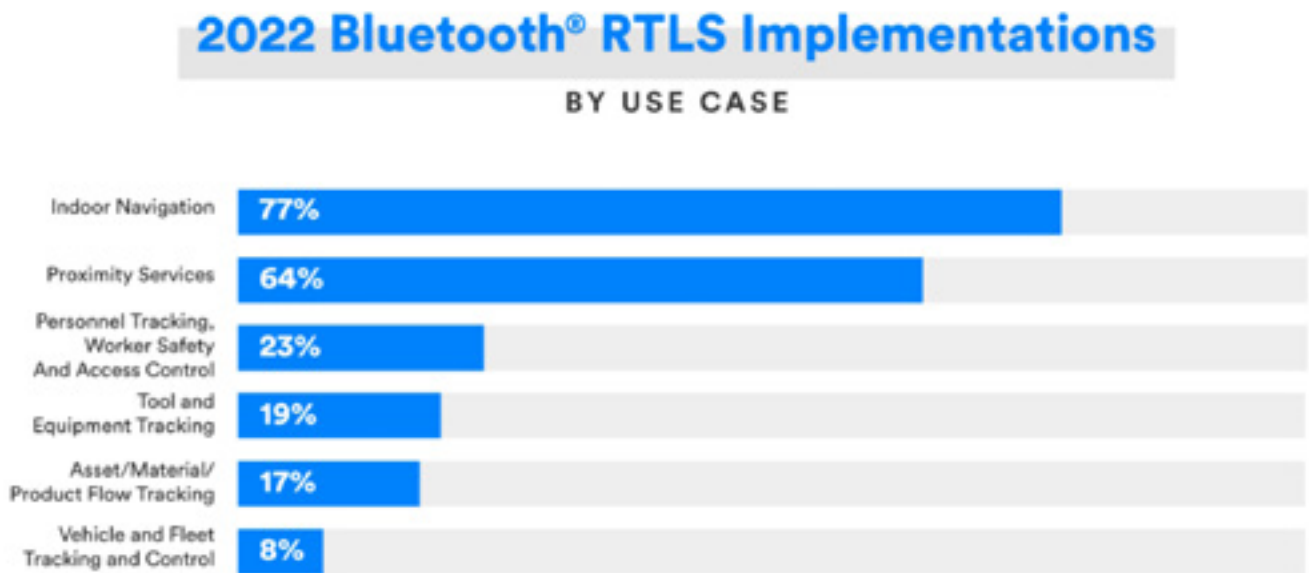

Date Source: ABI Research, 2022

Fig. 2. 128 million Bluetooth asset tracking devices will be shipped in 2022. (Image: Bluetooth SIG)

BLUETOOTH DIRECTION-FINDING

Bluetooth 5.1 uses two direction-finding methods in positioning applications. In one method, the object to be located sends a signal that is received by the 'locator'. The tracking device is then able to determine the direction to the object. This is the Angle of Arrival (AoA) procedure.

In another method, the object to be located receives the signal sent by multiple beacons. In this case, it can determine a direction to the beacons. This is called an Angle of Departure (AoD) calculation.

The first method can be used to find an item in places such a warehouse. The second method is useful when the object wants to know its position without showing its location to others. For example, a customer may want to determine their position in a shopping mall; they can use their smartphone and the signal from some beacons, without sending a signal themselves and revealing their location.

ANGLE OF ARRIVAL (AOA)

The complicated theory of direction-finding can be simplified to the following statement: when multiple receiving antennas are placed side by side, the radio waves emitted by a single transmitter reach different antennas on different phases. We can use this phase difference to calculate the direction from which the signal comes. Since the angle is determined relative to the receiver, this use case is called an estimate of the Angle of Arrival (Fig. 3).

Assuming that the incoming signal does not change its frequency during the measurement (i.e. is unmodulated) and the distance between the receiving antennas is less than half the wavelength, the phase difference clearly determines the angle of incidence.

For this method:

- The asset sends an unmodulated narrowband signal for a certain period of time.
- The locator scans the received signal on several antennas.

In practice, the receiver must have multiple input channels or use an RF switch (multiplexer) to take samples from each individual channel. The samples are called 'IQ samples' because a sample pair of 'in-phase' and 'quadrature-phase' measurements are taken from the same input signal. These samples have a 90-degree phase difference in sampling. If this pair is considered a complex value, each value contains both phase and amplitude information and can be an input for the arrival angle estimation algorithm.

Radio waves propagate at the speed of light; 300,000 km/s. At frequencies around 2.4 GHz, the corresponding wavelengths are about 0.125m. The maximum distance between two adjacent antennas is half a wavelength for most estimation algorithms. Many algorithms require this to avoid similar effects to aliasing. There is no theoretical limitation of the minimum distance, but in practice the minimum size is limited by the mechanical dimensions of the array (plus, for example, a mutual coupling between the antenna elements).

ANGLE OF ARRIVAL

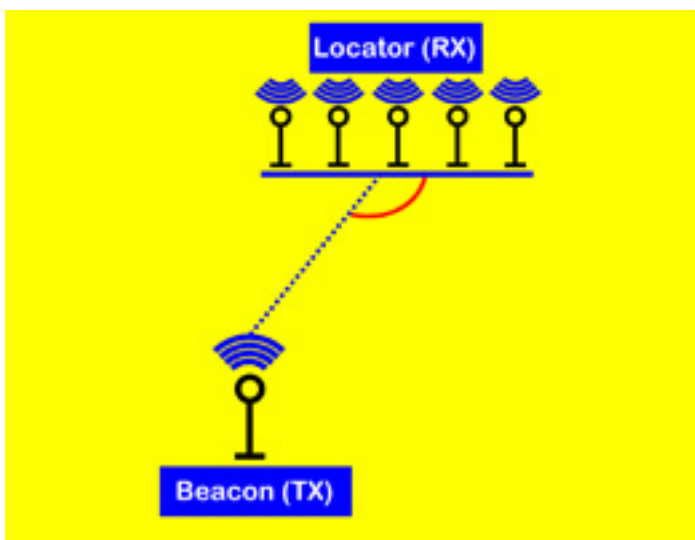

Fig. 3. Objects send their signal and tracking devices measure the angle of incidence of the signal. (Image: channel-e)

ANGLE OF DEPARTURE

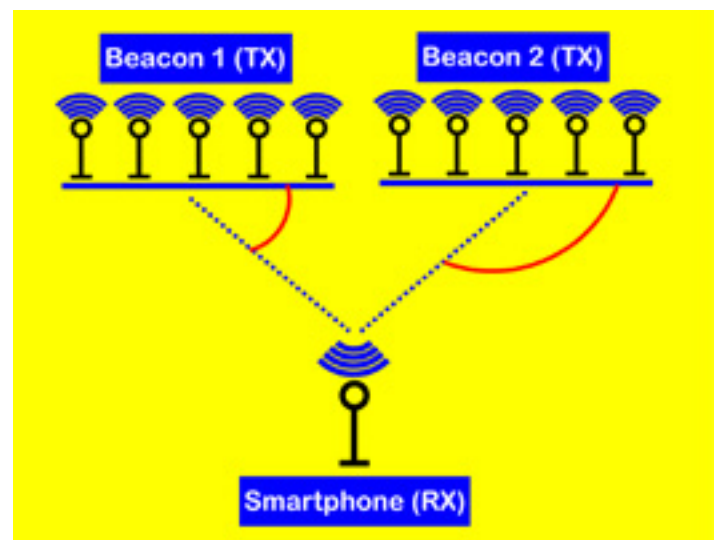

Fig. 4. Beacons transmit AoD information over multiple antennas. Mobile devices such as smartphones receive the beacon signals and calculate the position. (Image: channel-e)

ANGLE OF DEPARTURE (AOD)

The setup can also be reversed. When multiple antennas send waves on the same starting phase, a single antenna can measure the phase differences of the different incoming waves and calculate their own direction relative to the transmitting antenna array.

Since the angle is now determined relative to the transmitter, this application is called the AoD estimation (Fig. 4).

It is important that transmitters (beacons) must transmit with each antenna at the same frequency, as this is a prerequisite for the angle calculation. This also means that the antennas cannot transmit at the same time because their signals would interfere with one another. To solve this problem, the transmitting device must switch sequentially between the transmitting antennas, and the receiving side must know the configuration of the antenna group and the switching sequence.

For this method:

- The beacon transmits an unmodulated signal on several antennas in the time multiplex, i.e. it sends only one antenna at a time.
- The asset (e.g. a smartphone) scans the signal of several antennas with the same time division.

The two methods differ significantly in their application. With AoD, the receiver is able to calculate its own position in the room by using angles from multiple beacons and their positions (by triangulation).

With AoA, the receiver tracks the angles of arrival for individual objects. However, because the two methods can be combined in different ways, there is no limit to what can be done at application level. With both Bluetooth AoA and AoD, the associated control data is sent via a conventional data channel. Typically, these techniques can achieve an angular inaccuracy of a few degrees and a positioning inaccuracy of about 0.5m. However, these figures depend heavily on the implementation of the positioning system.

TRACKING APPLICATIONS IN AN IDEAL WORLD

As we have shown, calculating angular estimates in an ideal environment is no trivial matter. The honest truth is, they must also be calculated in environments with strong multipath effects, where signals are strongly correlated or coherent. A coherent signal is a signal that is delayed and is a scaled version of another signal. This can happen, for example, when radio waves are reflected off walls.

Another challenge is signal polarisation. In most cases, the polarisation of a mobile device cannot be controlled, so the system must take this into account. Signal noise, clock jitter and signal propagation delays also add their own variables to the problem. Depending on the size of the system, the RAM and especially CPU requirements for an embedded system can be high. Many of the algorithms for estimating the effective angle require considerable processing power from the CPU. A suitable angle estimation algorithm must take into account all these problems and apply advanced techniques to minimise their adverse effects.

FOR DEVELOPERS: HARDWARE AND SOFTWARE FOR BLUETOOTH LOCATION SERVICES

Silicon Labs has developed a hardware and software solution for Bluetooth location services that determine the location via the Angle of Arrival (AoA) and Angle of Departure (AoD).

The combination of hardware and software consists of the SIP modules BG22 and SoCs, which can be operated with a button cell for up to ten years. The software optimises indoor navigation, allows you to track objects and locate tags with an accuracy of less than one metre.

THE FUNCTIONS OF THE MODULE

- Asynchronous Continuous Tone Extension (CTE) transmissions from the device to the receiver (locator). Asynchronous transmission eliminates the need for synchronised transmission times between the end and location device. As a result, the tracking devices track a large number of objects simultaneously.
- Broad-spectrum CTE transmission across all 37 channels reduces interference by shifting CTE transmission from advertising to data channels.

Bluetooth software capabilities include these functions for the development of direction-finding applications. Development tools are available to speed up directional measurement applications. The product family offers a transmitting/receiving current of 4.1mA TX at 0 dBm, 3.6mA RX and is based on an ARM Cortex-M33 core (27 μ A/MHz active, 1.2 μ A at rest).



Fig. 5. The Silicon Labs Direction Finding Antenna Array used in SiLabs' Bluetooth direction-finding solution. (Image: Press image: Silicon Labs)



Fig. 6. The [EFR32BG22 module](#) is used in the Silicon Labs Bluetooth direction-finding solution. (Image: Press image: Silicon Labs)

SILICON LABS' COMPLETE BLUETOOTH LOCATION SOLUTION INCLUDES:

- EFR32BG22 and EFR32BG24 Bluetooth SoCs and modules
- Bluetooth stack with direction-finding
- AoA/AoD antenna array board and reference design
- Bluetooth locator and asset tag sample application
- Bluetooth direction-finding tools including AoA analyser and positioning tool

Based on documents from
Silicon Labs
Bluetooth SIG